

CHRISTMAS TREE STAND BOX

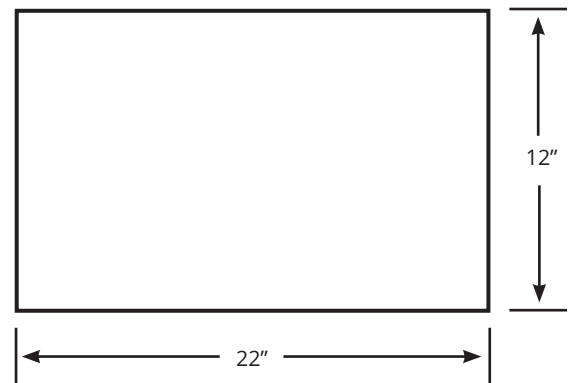
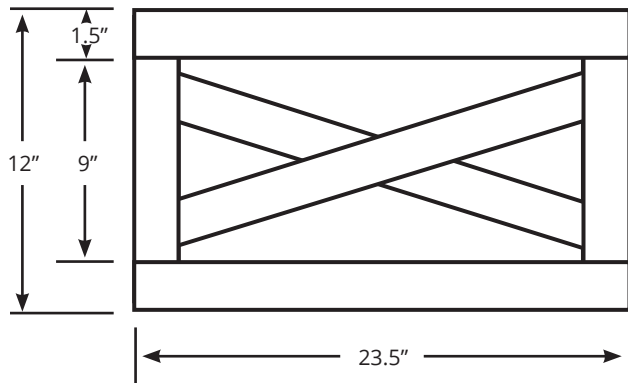

Trim on left, panel on right.

Dimension can be adjusted to your needs (size of Christmas tree stand or materials available).

CUT LIST:

- Panels 4 × 22" × 12"
- Horizontal trim 8 × 23.5" × 1.5"
- Vertical trim 8 × 9" × 1.5"
- Diagonal trim 8 × 23" × 1.5"
(approx. dimension; ends will need to be cut to fit)

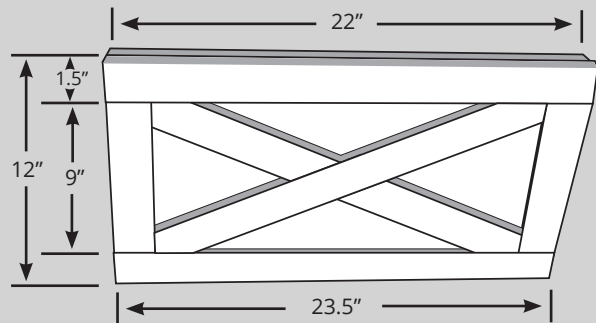

1. Cut four panels to size (ours were 12"h × 22"w).
2. Cut trim frame and put in place (our pieces of 1 × 2 were cut to 23.5" for horizontal and 9" for vertical). Be sure to extend trim past the sides of the panel by the thickness of the trim. This will cover the panel end grain when assembled.
3. Place diagonal trim brace on top of trim frame an mark location of cut line.
4. Cut trim to length.
5. Sand all edges.
6. Place trim on panel in correct location.
7. Apply glue to back of trim and fasten with brad nails (or use a hammer and nails or screws).
8. Once the four sections are nailed and glued, set aside to let glue dry and prepare for finishing.
9. You can paint or stain using any finish; we used oyster white milk paint (53Z5012).
10. Mix milk paint dry powder with water and stir until all clumps dissolve.
11. Paint four sections of box.
12. Apply second coat and let paint dry.
13. Dry-fit four sections and mark centers in corners for hardware locations.
14. Screw mortise-free bedlocks (00S1735) into place.